

Voltage-Dip Compensators

**For VDC L4T & S4T series Models
120V / 208V / 220V / 230V 50/60Hz**



Contents

Introduction	3
Theory of operation	3
Specifications	5
VDC support for the SEMI F47 standard	7
Installation Guide	9
Power Wiring	9
Indicator error codes	11
Adjustments	11
Compensator Run Time	11
I ² t controlled run time curves	12
Fault Diagnosis Chart	13
Mechanical Construction	16
Dimension Table	16
Mechanical Outline	17
Accessories	18
Voltage Sag Simulator	19

Notice

IMPORTANT SAFETY INSTRUCTIONS. SAVE THESE INSTRUCTIONS!

This manual contains important instructions that should be followed during installation and adjustment of VDC series Voltage Dip Compensators.

Introduction

The reliability of electrical power to industry is in general very high, nevertheless, voltage sags or dips do occur. These instabilities are caused by short circuits, lightning strikes on overhead power lines and heavy load switching. The duration of such faults is generally shorter than one second. Power Quality data shows that voltage sags with a maximum depth of around 50% constitute 92% of all events.

Most plant can ride through such voltage dips by virtue of their mechanical and electrical inertia. However, this is not the case with electrically held-in contactors and relays that control the machinery. Contactors typically drop out from 5ms to 20ms after power is removed. Each short voltage dip now becomes a power failure and the plant must be restarted. This can be complicated, time-consuming and costly.

SWITCHING SYSTEMS' Voltage Dip Compensators are designed to maintain the switchgear control voltage during voltage sags, effectively keeping the plant connected. The stored electrical and magnetic energy is allowed to flow, supporting the mechanical inertia of the machinery. When the power is restored after a short voltage dip, the plant is still running at near synchronous speed, the inrush currents will be small and the stress to the system minimal. The VDC provides an economic solution for users who need their equipment to comply with the Semi F47 standard for voltage sag immunity.

Historically, this problem has been addressed by using DC contactors, latched contactors and intelligent controls such as PLC's. These systems are complex and expensive and do not provide a solution for equipment already in existence. The current approach to this problem has been to employ intelligent control systems which provide a curative solution. In contrast, the Voltage Dip Compensator, provides a preventative solution.

Theory of operation

The VOLTAGE-DIP COMPENSATOR is designed to be maintenance free and highly reliable. It consists of 5 static switches , a sag compensation transformer and the controls. The Voltage Dip Compensator block diagram is shown in Fig 1 below.

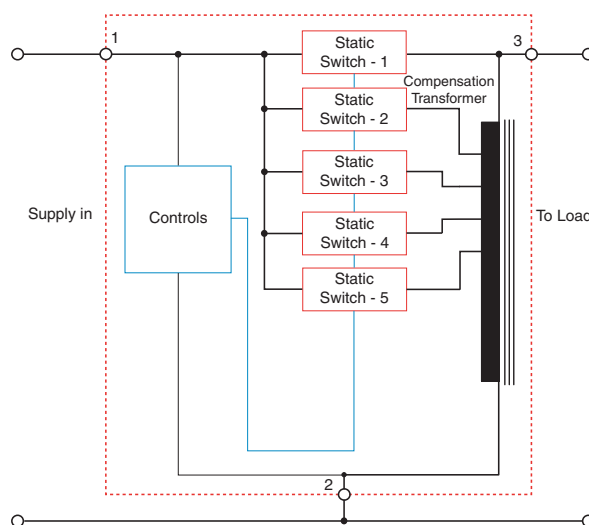

Fig 1
Compensator Block Diagram

The STATIC SWITCHES are robust and can withstand large current surges. They are ideally suited for contactor operation where high peak currents of short duration occur during energizing.

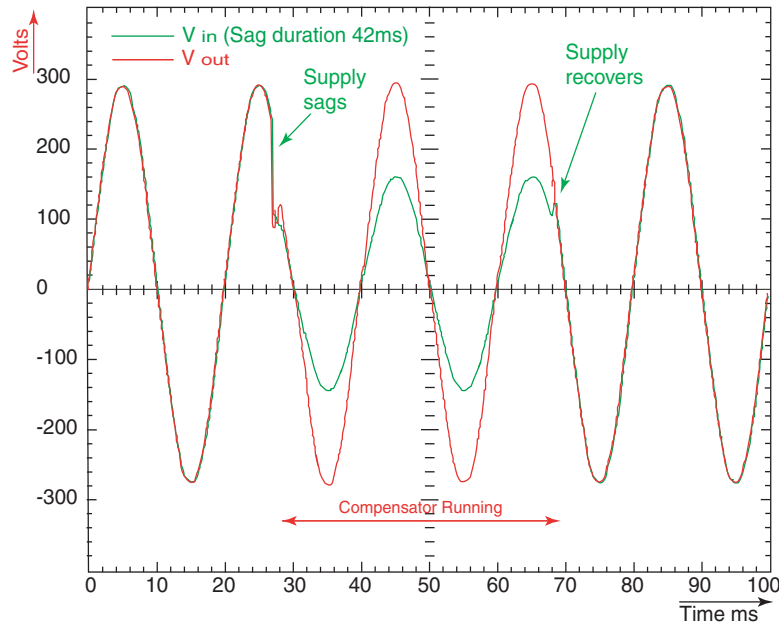

Fig 2
Compensator output waveform.

During stand-by operation, static switch1 supplies power directly to the load,static switches 2 to 5 are switched off and the compensation transformer carries no load. The supply voltage is constantly monitored for deviations; should there be a deviation from V_{nom} which is greater than $\pm 10\%$, static switch 1 is switched off and static switch 2 is activated. Depending on the sag depth the controls will operate static switches 2 to 5 to maintain the compensator output voltage within $\pm 10\%$ of the nominal supply voltage. The switch-over is accomplished in $350\mu s$. A 3.15 second timer, adjustable in increments of 50ms, starts timing the compensator out. Should the input voltage recover within the set time, static switches 2 to 5 will be deactivated and static switch 1 will be switched on and the load is reconnected to the supply. If the input voltage does not recover within the set time the load is switched back to the supply regardless of the voltage level. If I^2t control is enabled then the run time will be dynamically optimized to the longest time that load conditions will allow.

The VDC employs tap switch fuses to prevent catastrophic damage to the unit in the event of a tap switch failure. If a tap switch should fail the fuse will open. A VDC with a failed tap switch will continue to function normally and will attempt to serve any sags that occur. However if sag conditions require activation of the failed tap then the load will be dropped because there is no output from that tap.

Specifications

VDC L4T & S4T series 120V models

		120V MODELS												
		VDC S4T1K120						VDC L4T3K120						
AC INPUT SUPPLY														
Single phase supply voltage 50/60Hz:														120V
Maximum input voltage:														+10%
Minimum input voltage:		-50%				-50%								
Full load current (A RMS):		8.5A				24A								
Maximum surge current for 3 seconds duration:														550A
AC OUTPUT														
Nominal output voltage:														120V
Voltage fluctuations over full operating range:														± 10%
Nominal load current (A):		8.5A				24A								
Power factor range:														cos Φ from 1 to 0
Wave shape:														Sinusoidal
Nominal load (VA):		1000				3000								
Maximum up-time (sec):														
Timer control:														3.15s
I ² t control:														See Figs 9 & 10 p12
Overload current limit (A RMS):		12A				35A								
Short circuit current limit (A RMS):		30A				75A								
TIMER														
Range:														0.05 to 3.15s
Setting:														0.05s steps
INDICATORS														
System OK:														green LED
Compensator running:														red LED
TEMPERATURE														
Maximum ambient working temperature:														45°C (113°F)
CUBICLE														
Construction:														Extruded Aluminum
Height (mm) (Dim. L3 on p10):		280				273								
Height (in) (Dim. L3 on p10):		11.02				10.75								
Width mm (in):		150 (5.90)			311 (12.24)									
Depth mm (in):		110 (4.33)			162 (6.38)									
Mass (kg):		5.0				9.0								
Mass (lbs):		11.0				19.8								
CONNECTION														
Cable, Copper panel wire; size mm ² :		2mm ²			5mm ²									
Cable, Copper panel wire; size AWG:		14 AWG			10 AWG									
Screw terminal torque Nm (lb-in):														1.76Nm (15.6lb-n)
LISTINGS														
Underwriters Laboratories Inc:														
STANDARDS SUPPORTED														
SEMI F47:														Semiconductor processing equipment voltage sag immunity.

The VDC family is designed for applications that must meet the SEMI F47 Voltage Sag Immunity Standard for Semiconductor Processing Equipment and where size and cost are critical factors.

Installation & Service Manual

Specifications

VDC L4T & S4T series 208V / 220V / 230V models

	208 / 220 / 230V MODELS											
	VDC S4T1K208		VDC L4T5K208		VDC S4T1K220		VDC L4T5K220		VDC S4T1K230		VDC L4T5K230	
AC INPUT SUPPLY												
Single phase supply voltage 50/60Hz:	208V				220V				230V			
Maximum input voltage:	+10%											
Minimum input voltage:	-50%	-50%	-50%	-50%	-50%	-50%	-50%	-50%	-50%	-50%	-50%	-50%
Full load current (A RMS):	4.8A	24A	4.6A	22.7A	4.3A	21.7A						
Maximum surge current for 3 cycles duration:	550A											
AC OUTPUT												
Nominal output voltage (V):	208V				220V				230V			
Voltage fluctuations over full operating range:	± 10%											
Nominal load current (A):	4.8A	24A	4.6A	22.7A	4.3A	21.7A						
Power factor range:	cos Φ from 1 to 0											
Wave shape:	Sinusoidal											
Nominal load (VA):	1000	5000	1000	5000	1000	5000						
Maximum up-time (sec):												
Timer control:	3.15s											
I ² t control:	See Figs 9 & 10 p12											
Overload current limit (A RMS):	12A	28A	12A	28A	12A	28A						
Short circuit current limit (A RMS):	35A	75A	35A	75A	35A	75A						
TIMER												
Range:	0.05 to 3.15s											
Setting:	0.05s steps											
INDICATORS												
System OK:	green LED											
Compensator running:	red LED											
TEMPERATURE												
Maximum ambient working temperature:	45°C (113°F)											
CUBICLE												
Construction:	Extruded Aluminum											
Height (mm) (Dim. L3 on p10):	280	293	280	293	280	293						
Height (in) (Dim. L3 on p10):	11.02	11.54	11.02	11.54	11.02	11.54						
Width mm (in):	150 (5.90)	311 (12.24)	150 (5.90)	311 (12.24)	150 (5.90)	311 (12.24)						
Depth mm (in):	110 (4.33)	162 (6.38)	110 (4.33)	162 (6.38)	110 (4.33)	162 (6.38)						
Mass (kg):	5.0	9.0	5.0	9.0	5.0	9.0						
Mass (lbs):	11.0	19.8	11.0	19.8	11.0	19.8						
CONNECTION												
Cable, Copper panel wire; size mm ² :	2mm ²	5mm ²	2mm ²	5mm ²	2mm ²	5mm ²						
Cable, Copper panel wire; size AWG:	14AWG	10AWG	14AWG	10AWG	14AWG	10AWG						
Screw terminal torque Nm (lb-in):	1.76Nm (15.6lb-in)											
LISTINGS												
Underwriters Laboratories Inc:												
STANDARDS SUPPORTED												
SEMI F47:	Semiconductor processing equipment voltage sag immunity.											

The VDC family is designed for applications that must meet the SEMI F47 Voltage Sag Immunity Standard for Semiconductor Processing Equipment and where size and cost are critical factors.

VDC support for the SEMI F47 standard

This standard was drafted by the Semiconductor Industry to specify Voltage Sag Immunity requirements for semiconductor processing equipment. The profile for the F47 standard is shown in Fig 3.

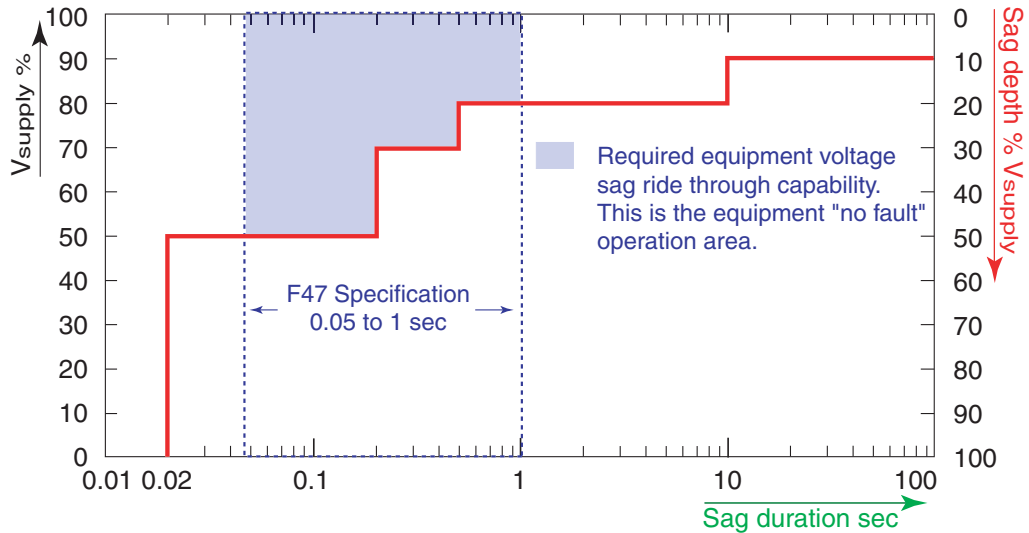

Fig 3
SEMI F47 Standard.

The blue zone represents the operation area where no equipment faults must occur due to voltage sags on the supply. The “no fault” window is from 50ms to 1 second with variable depth sag to a maximum of 50% of the nominal supply voltage.

The VDC family is designed for applications that must meet the SEMI F47 Voltage Sag Immunity Standard for Semiconductor Processing Equipment and where size and cost are critical factors.

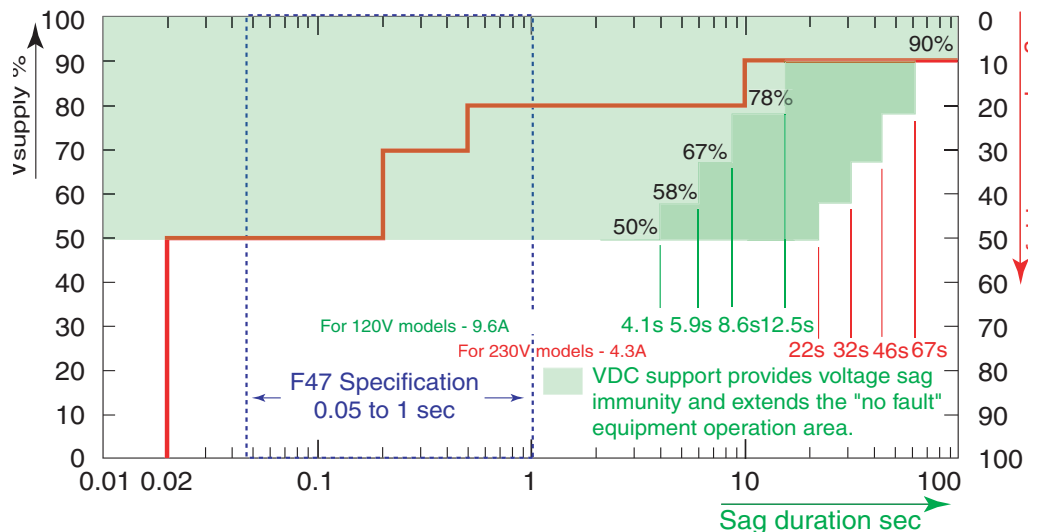

Fig 4

VDC extended support for the SEMI F47 Standard. Times shown are for the VDC S4T series with $I_{load} = 9.6A$ for 120V models, $I_{load} = 4.3A$ for 230V models & duty cycle 1 maximum length event every 20 minutes.

The green area in Fig 4 shows the extended support provided by the VDC S4T series. Support times are shown in green for 120V models at a load current of 9.6 amps and in red for 230 models at a load current of 4.3 amps. The “no fault” window is extended

from 50ms to 4.1 & 12.5 seconds respectively with a maximum continuous sag depth of 50%. VDC L4T3K/5K support times are shown in Fig 5.

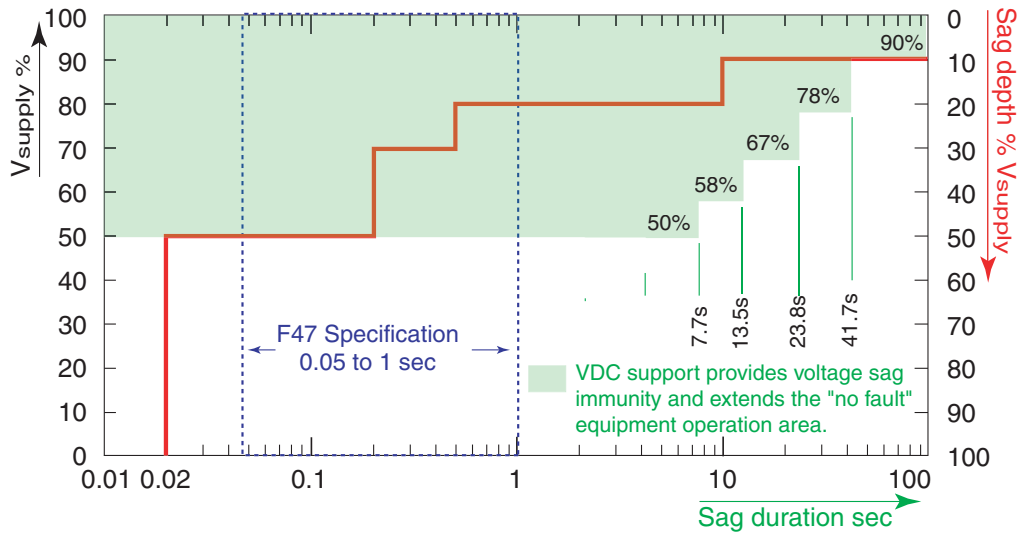

Fig 5

VDC extended support for the SEMI F47 Standard. Times shown are for the VDC L4T 3K/5K series with $I_{load} = 24A$ & duty cycle 1 maximum length event every 7 minutes.

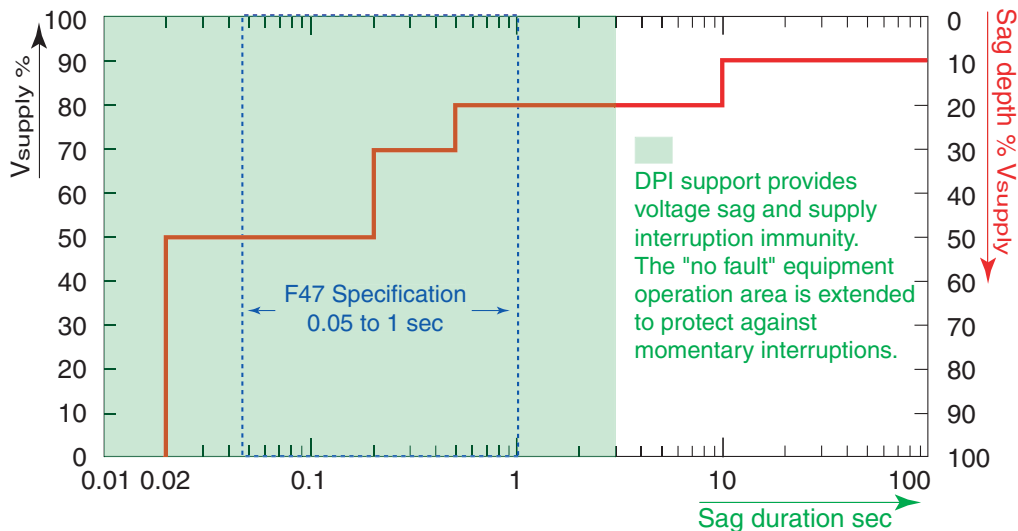

Fig 6

DPI support for the SEMI F47 Standard.

For applications that require protection against momentary interruptions and sags refer to our **Voltage Dip Proofing Inverter (DPI)** product line for a simple cost effective solution that is easy to intergate into OEM products or retrofit to existing equipment. The DPI support profile is shown together with the F47 curve in Fig 6. It can be seen that the DPI provides complete protection for all sag depths and interruptions from 0 to 3 seconds.

Installation Guide

1. Remove the unit from its packing
2. Place the unit horizontally on a bench and visually check for any mechanical damage. Ensure that all the casing screws are tight then shake the unit to check that there is nothing loose internally.

Note : Please inform your shipping agent if any damage has occurred during transit : the damaged unit(s) and all packing material should be kept in case the insurers wish to inspect the damage.
3. Check that compensator voltage is the same as the system control voltage.
Refer to the rating label on the unit end plate.

WARNING: Never connect a 120V unit to a 208V or 230V supply!

4. Decide on the location where the unit is to be installed, this will probably be inside a switch gear panel.
5. Mount the unit vertically using M6 bolts.
6. Connect unit as shown in Fig 7 using 2mm² (14AWG), VDC S series & 5mm² (10AWG), VDC L series copper panel wire.
7. Apply terminal screw tightening torque of 1.5 - 1.8Nm (13 - 16 lb-in).
8. This device does not have a disconnect switch. If such a switch is required it must be provided by others.

Power Wiring

Connect Line In (Supply)	to	Terminal 1
Connect Common Line in	to	Terminal 2
Connect Common Line out	to	Terminal 3
Connect Line Out (Load)	to	Terminal 4

Connect the ground screw(s) to the panel ground point.

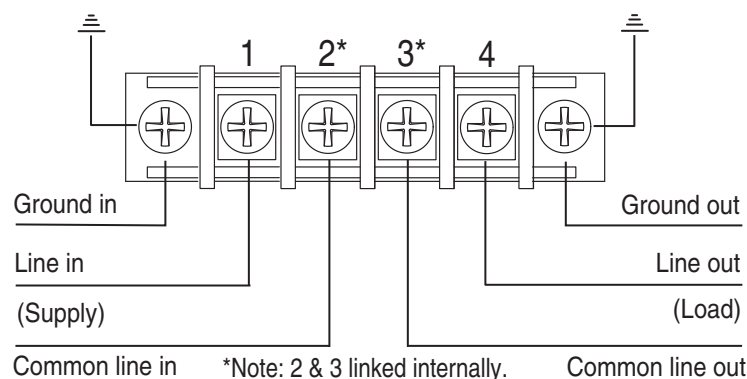

Fig 7
Power Wiring Diagram

Installation & Service Manual

9. Once the unit has been mounted and the external wiring completed, power can be applied. Turn on the power to the unit. The green LED indicator "System OK" will come on after approximately one second and the unit is fully operational.
10. In applications which require no break maintenance, a bypass switch must be installed. Order the appropriate Bypass Switch (see p17) which should be connected as shown in Fig 8.

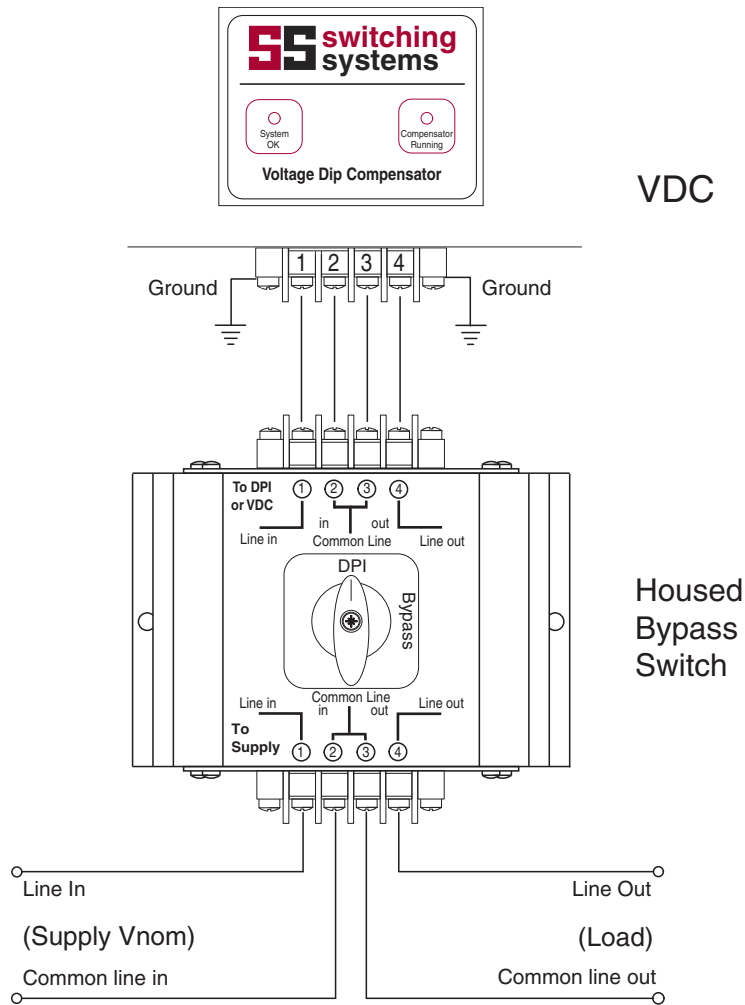

Fig 8
Housed Bypass Switch Connection Diagram

Functional Description of the Indicators



System OK : Green LED indicator

When the green LED is ON the system is fully functional; the unit self test & initialization routine has been run successfully.

Compensator Running : Red LED indicator

The red LED is on when the compensator is running during a voltage dip.

Indicator error codes

Indicator	Flashes			Condition
	1	2	Profile	
System OK Green	✓			Event not fully supported. Resets after 24 hours.
Start up Test. System OK Green		✓		Supply check, AC input low.
Compensator running Red	✓			Load current check, overload.

Test and Maintenance

There are no user serviceable parts inside the unit, if faulty return to factory or local agent for repairs.

Adjustments

Adjustment points are marked on the control card and can be reached by removing the front cover of the VDC; see Mechanical Construction on page 15.

Compensator Run Time

Timer controlled Run Time - SW1 (see Fig.11 page 13)

This switch sets the running time of the compensator and can be set in 50ms steps to a maximum of 3.15 seconds. To determine the run time which is currently set, add the figures printed next to each switch that is in the ON position. For example, a running time setting of 3.15 seconds requires these switch combinations: 1-on, 2-on, 3-on, 4-on, 5-on, 6-on.

I²t controlled Run Time.

Run Time is dynamically optimized to the longest that load conditions will allow.

The I²t optimized Run Time can be determined using the curves on page 12.

To enable this option set all SW1 switches to OFF.

Factory Setting : I²t control (SW1 1-6- off)

I²t controlled run time curves

Use the curves below (Fig 9 for “S” series & Fig 10 for “L” series) to determine the I²t controlled run times for a specific load current and sag depth.

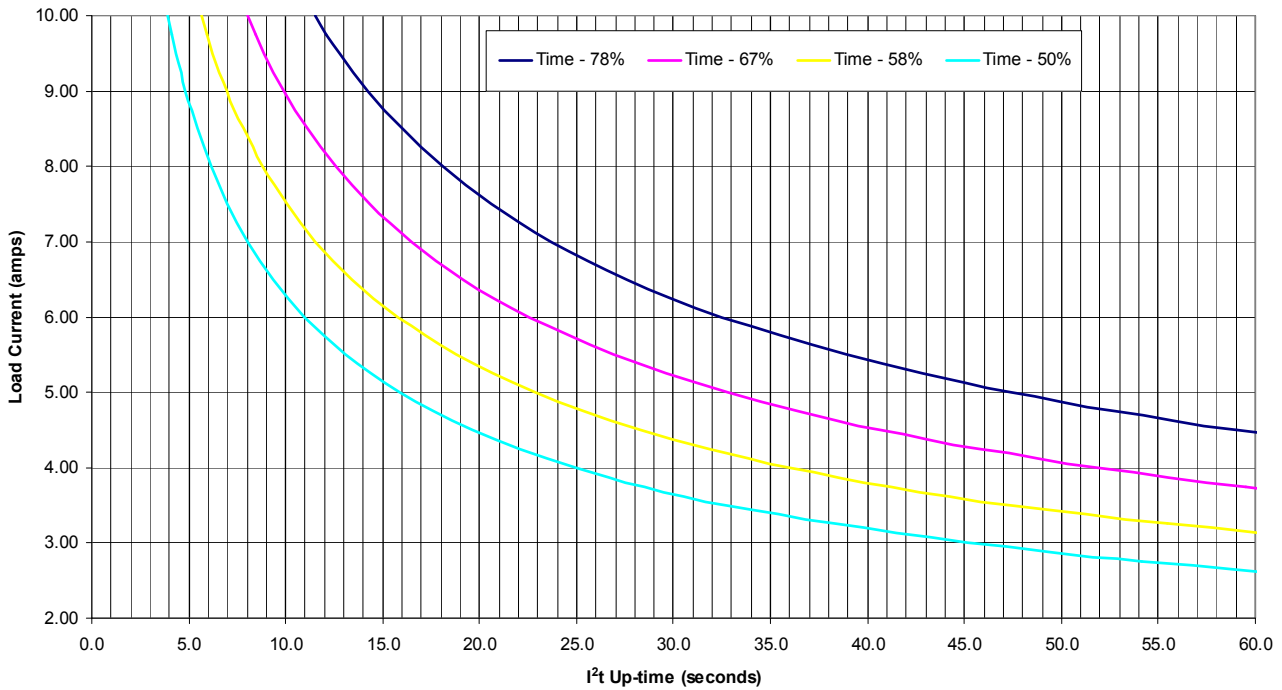

Fig 9
Maximum I²t controlled Up-times for VDC S4T1K series.
Duty cycle 1 maximum length event every 20 minutes.

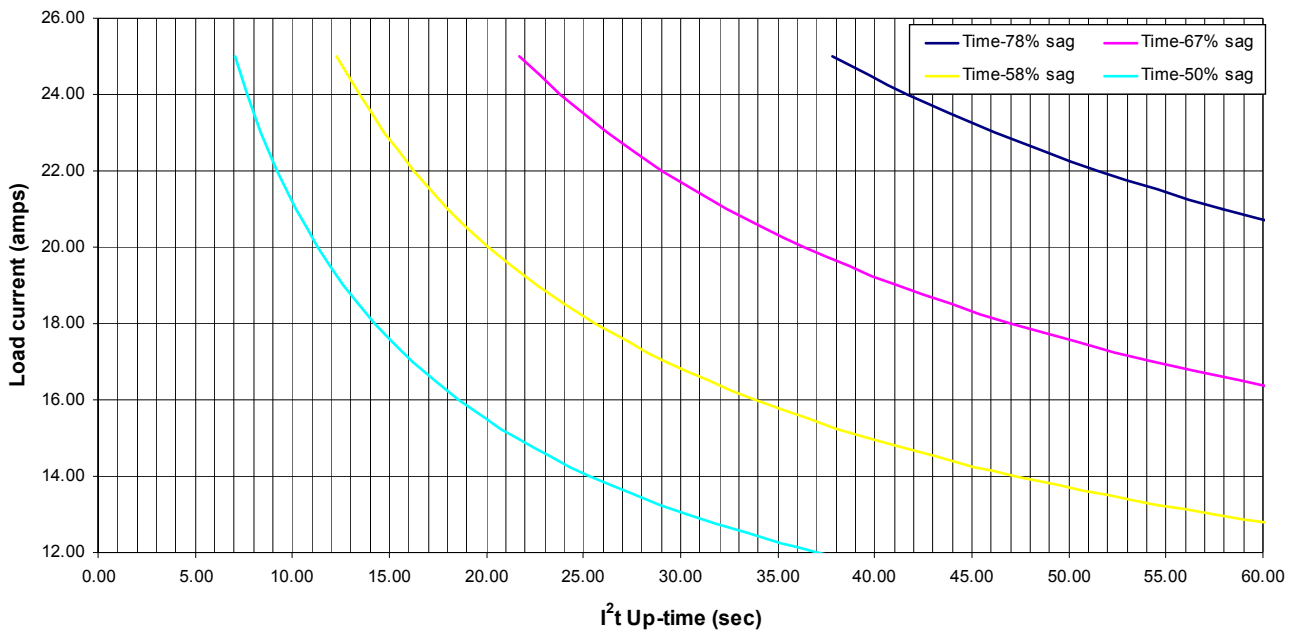

Fig 10
Maximum I²t controlled Up-times for VDC L4T3K & VDC L4T5K series.
Duty cycle 1 maximum length event every 7 minutes.

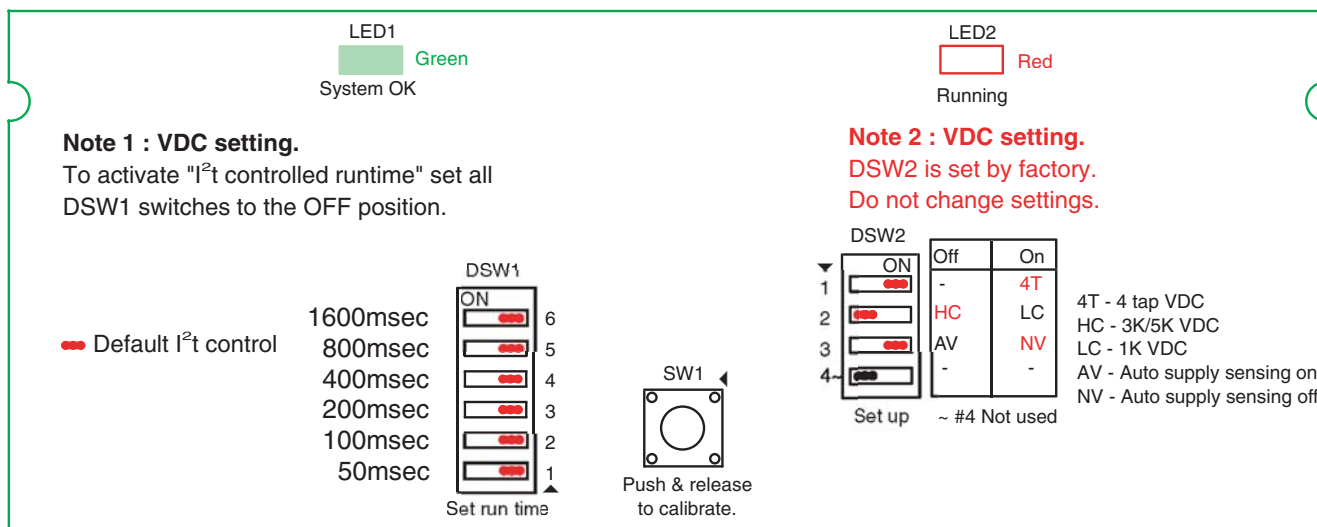

Fig 11
Control Card Indicator & Adjustment Locations

Fault Diagnosis Chart

Symptom	Probable Cause	Remedy
System OK LED (green) is off, no voltage on output terminals.	No supply voltage on input terminals 1 & 2.	Check supply.
System OK LED (green) is off. Compensator Running LED (red) flashes once every second. There is no voltage on output terminals 3 & 4.	Overload condition, load current exceeds unit overload rating.	Check load current, if it exceeds the Overload rating eliminate any devices that do not need to be supported or use a larger unit.
System OK LED (green) is off, voltage on terminals 3 & 4 no voltage on 1 & 2.	Supply and load wires are reversed. Terminals 1 & 4.	Swap supply & load wires. Supply terminal 1 and load terminal 4.
Powered up for > 3 seconds. System OK LED (green) is off. Compensator Running LED (red) is off. There may / may not be voltage on terminals 3 & 4.	Unit failure.	Return to local agent or manufacturer for repair.
System OK LED (green) flashes twice every second. voltage present on output terminals.	Low supply voltage. A 208/220/230V unit is being used with a 120V supply.	Change unit to 120V model.
Unit failure when supply switched on.	A 120V unit is being used on a 208V or 220V supply.	Change unit to correct voltage model. Note: The 120V unit will be damaged!

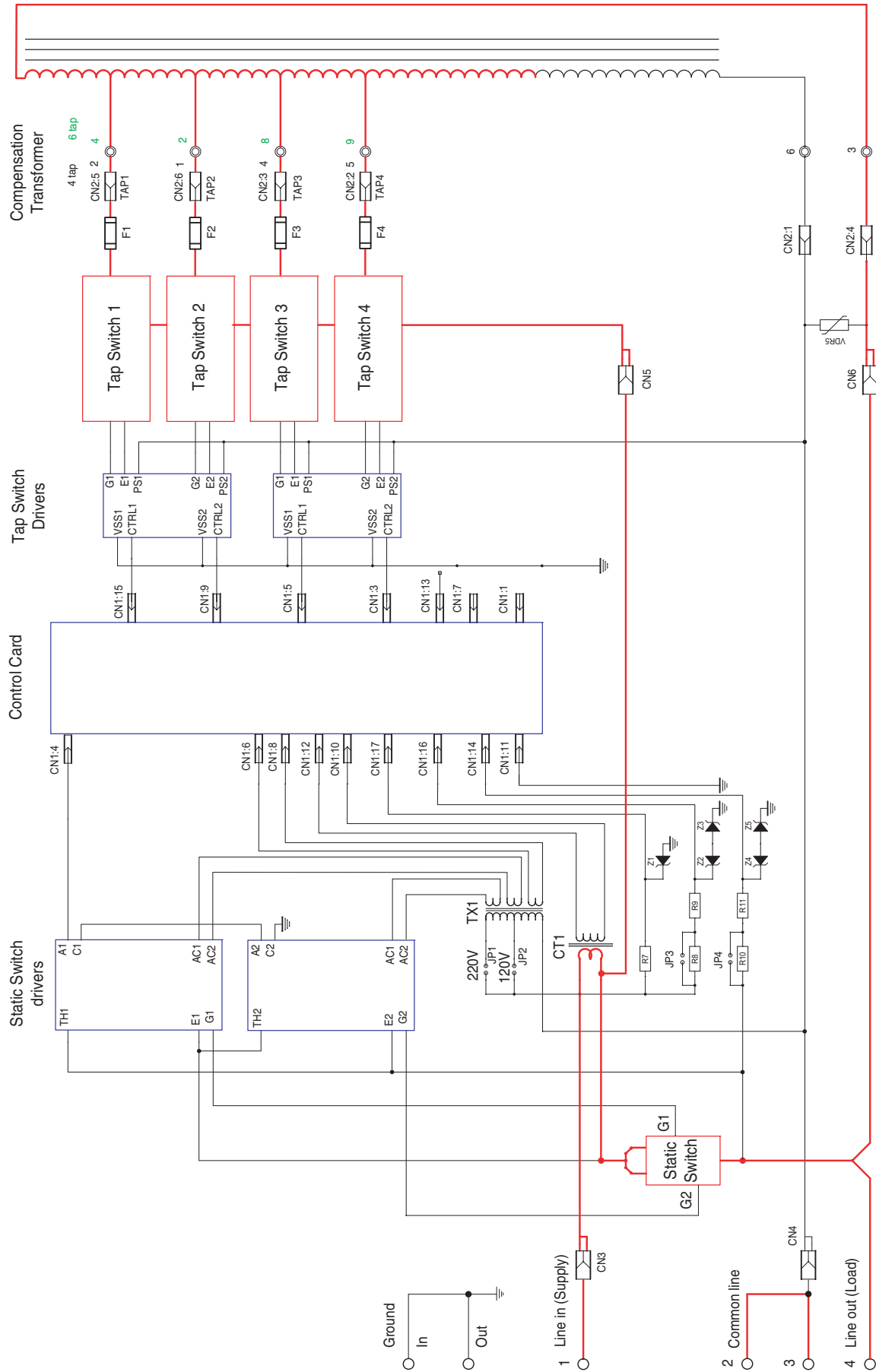

Fig 12
VDC Block Wiring Diagram

Notes

Installation & Service Manual

Mechanical Construction

VDC S series - The VDC case is made from extruded aluminium sections. The four parts that make up the case are interlocked and secured by screws. To remove the front cover unscrew four screws : the two top screws from the end plate where the terminal block is located and the two bottom screws from the other end plate. Slide the front cover away from the terminal block to access adjustment area.

VDC L series - The VDC case is made from extruded aluminium sections. The six parts that make up the case are interlocked and secured by screws. To remove the front cover unscrew three screws : one from the front cover and one each from the top and bottom end plates.

Dimension Table

Model	VDC Dimensions mm (in)							
	L1	L2	L3	L4	L5	L6	L7	D
VDC S4T1K120	177 (6.97)	237 (9.33)	280 (11.02)	110 (4.33)	150 (5.90)	30 (1.18)	140 (5.50)	6.0 (0.24)
VDC L4T3K120	170 (6.69)	250 (9.84)	293 (11.54)	162 (6.38)	311 (12.24)	40 (1.57)	296 (11.65)	8.0 (0.31)
VDC S4T1K208	177 (6.97)	237 (9.33)	280 (11.02)	110 (4.33)	150 (5.90)	30 (1.18)	140 (5.50)	6.0 (0.24)
VDC L4T5K208	170 (6.69)	250 (9.84)	293 (11.54)	162 (6.38)	311 (12.24)	40 (1.57)	296 (11.65)	8.0 (0.31)
VDC S4T1K220	177 (6.97)	237 (9.33)	280 (11.02)	110 (4.33)	150 (5.90)	30 (1.18)	140 (5.50)	6.0 (0.24)
VDC L4T5K220	170 (6.69)	250 (9.84)	293 (11.54)	162 (6.38)	311 (12.24)	40 (1.57)	296 (11.65)	8.0 (0.31)
VDC S4T1K230	177 (6.97)	237 (9.33)	280 (11.02)	110 (4.33)	150 (5.90)	30 (1.18)	140 (5.50)	6.0 (0.24)
VDC L4T5K230	170 (6.69)	250 (9.84)	293 (11.54)	162 (6.38)	311 (12.24)	40 (1.57)	296 (11.65)	8.0 (0.31)

Mechanical Outline

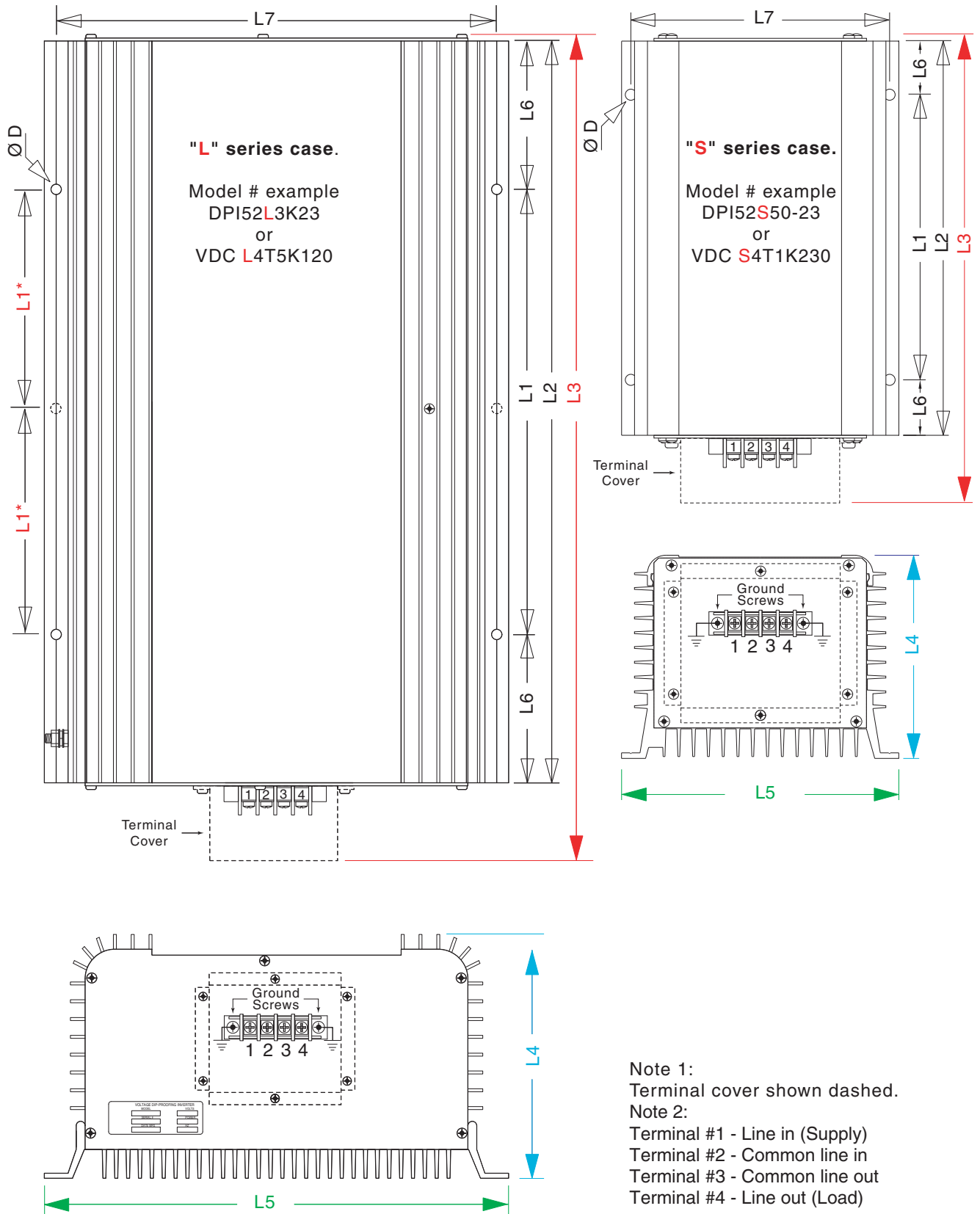

Fig 13
Dimensions of the VDC series mm (inches)

Installation & Service Manual

Accessories

Housed Bypass Switch

Description

Where no-break maintenance is required a by pass switch must be installed. It connects the supply directly to the load, "Bypass" position, and disconnects the power terminals of the inverter without interrupting the supply. When in "DPI" position the load is connected to the supply via the inverter.

Specifications

MODEL	BPSW25A
ELECTRICAL	
Maximum current:	25A
Maximum input voltage:	600Vac
TEMPERATURE	
Maximum working temperature:	45°C (113°F)
HOUSING	
Construction:	Extruded Aluminum
Height:	202mm (7.95in)
Width:	150mm (5.9in)
Depth:	141mm (5.55in)
Mass:	1kg (2.2lbs)

Mechanical outline

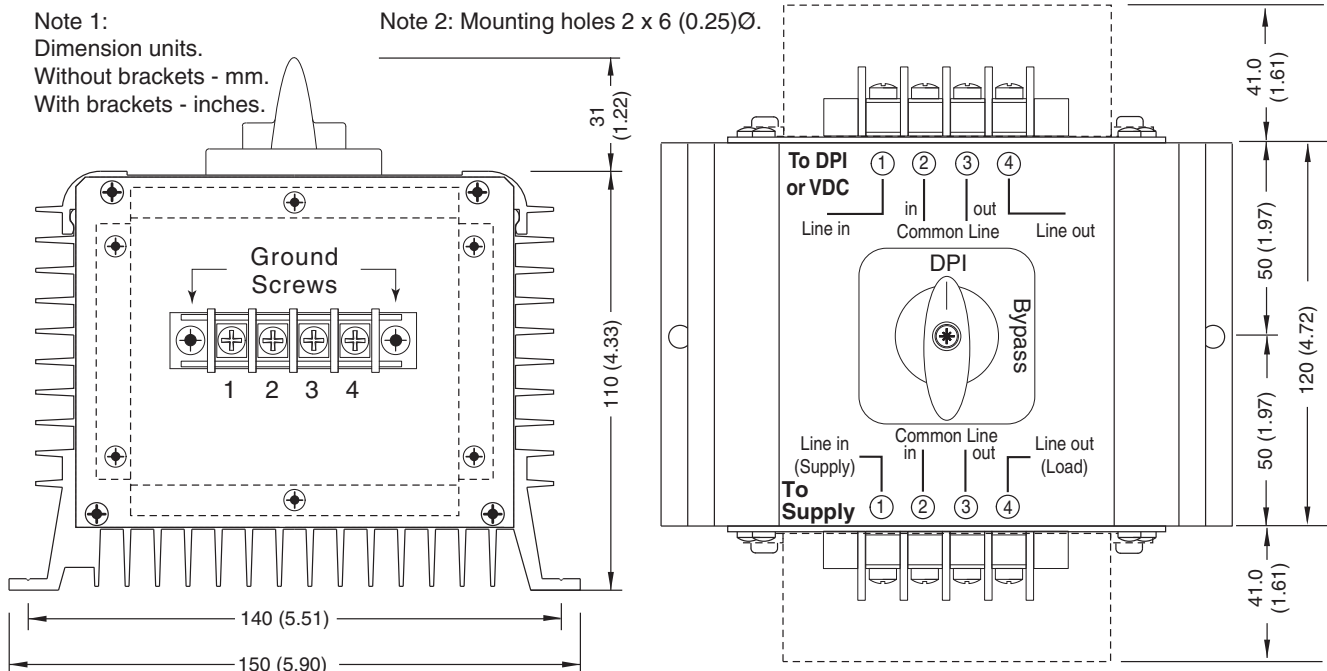

Ordering

Stock No:
5003-006

Description
Housed By-Pass Switch 25Amp

Voltage Sag Simulator

Description

The Sag Simulator is an effective tool to evaluate the effects of momentary voltage sags and interruptions on industrial controls. When used in conjunction with a Voltage Dip-Proofing Inverter or a Voltage Dip Compensator and Bypass switch, it may be used to prove the effectiveness of the DPI or VDC as a solution for these power quality problems.

The Sag Simulator is designed for 120/208/240Vac operation. The controls consist of a variac to set the sag depth, an LCD display to indicate the sag voltage value and program status, four programming keys to set up and operate the simulator. A variable interrupt timer sets the duration of the voltage sag and the point in the cycle at which it begins. Both variables are set using the programming keys and are indicated on the LCD display.

Simulator output is short circuit and overload protected. A 5V synchronization pulse is provided to trigger an oscilloscope. A photograph appears on page 8; the specifications are shown below.

Sag Simulator Specifications

AC INPUT SUPPLY

Supply voltage: 120/208/240Vac 50/60Hz
 Maximum input voltage: +10%
 Full load current: 20A

VARIAC CONTROL

Variac range: 0-240Vac RMS
 Maximum power: 1200VA @ 120V / 2400VA @ 240V
 Maximum continuous current: 10A Maximum short term current for 3 seconds: 20A
 Overload & short circuit protection: Yes

DIRECT VARIAC OUTPUT

Variac range: 0-240Vac RMS
 Maximum power: 1200VA @ 120V / 2400VA @ 240V
 Maximum continuous current: 10A
 Overload & short circuit protection: Yes

SAG DELAY TIMER

Range: 0.00 to 20.00 ms
 Setting: 0.01 ms steps

SAG DURATION TIMER

Range: 0.010 to 9.999 seconds
 Setting: 0.001 second steps

CONTROLS & INDICATORS

Programming: Four push switches
 Menu/parameter indicator: 4 x 20 LCD display

SYNC PULSE OUTPUT

Amplitude: 5V
 Polarity: Positive
 Electrically isolated output: Yes
 Duration: Equal to sag duration

TEMPERATURE

Maximum ambient working temperature: 45°C (113°F)

HOUSING

Construction: Extruded aluminium
 Height: 390mm (15.35in)
 Width: 311mm (12.24in)
 Depth: 162mm (6.38in)
 Mass: 15kg (33lb)

Simulated Sag Profile

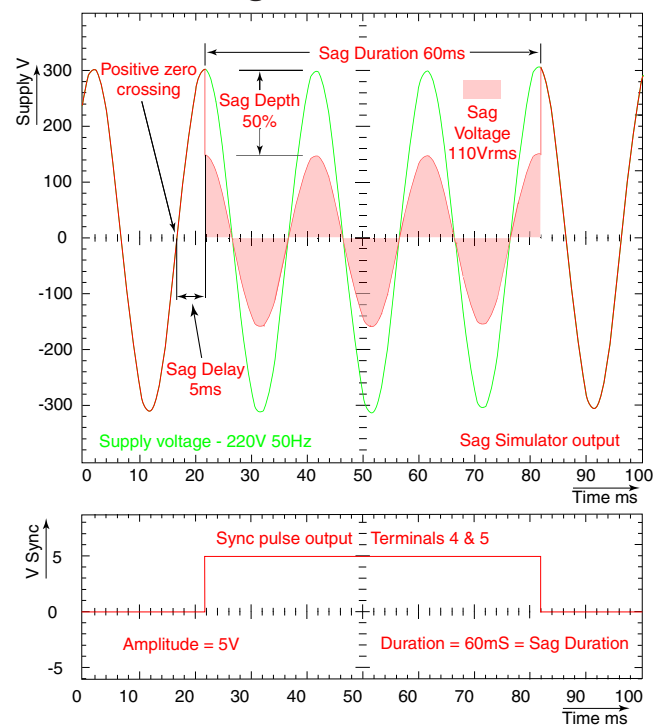

Voltage-Dip Compensators

For VDC L4T & S4T series Models
120V / 208V / 220V / 230V 50/60Hz

